

User Manual CX eco



Beluk GmbH
Taubenstrasse 1
86956 Schongau
Germany

Tel.: +49/(0)8861/2332-0
Fax.: +49/(0)8861/2332-22
E-Mail: blr@beluk.de
Web: <http://www.beluk.de>

 **DANGER**



General safety notes

Failure to observe the following instructions may result in serious injury or death!

There is a risk of electric shock during installation! Therefore, electrical devices may only be installed, operated, serviced and maintained by qualified professionals. A professional is someone who has the ability, experience and knowledge required for the construction, installation and operation of electrical equipment and who has been instructed in identification and avoidance of possible hazards.

During installation and maintenance, the relevant regulations for the installation of switchgear and accident prevention must be observed and adhered to.

Devices with damaged or open housings or terminals must not be operated on the power grid and must be disconnected immediately.

After disconnecting the device, 10 minutes must be waited until the capacitors have been discharged. Subsequently, doors or covers may be removed. It must be checked whether the disconnected area is voltage-free using a standardized measuring instrument.

Ther BELUK GmbH assumes no responsibility or warranty for damage to persons and equipment caused by improper installation and use.

Connection diagram

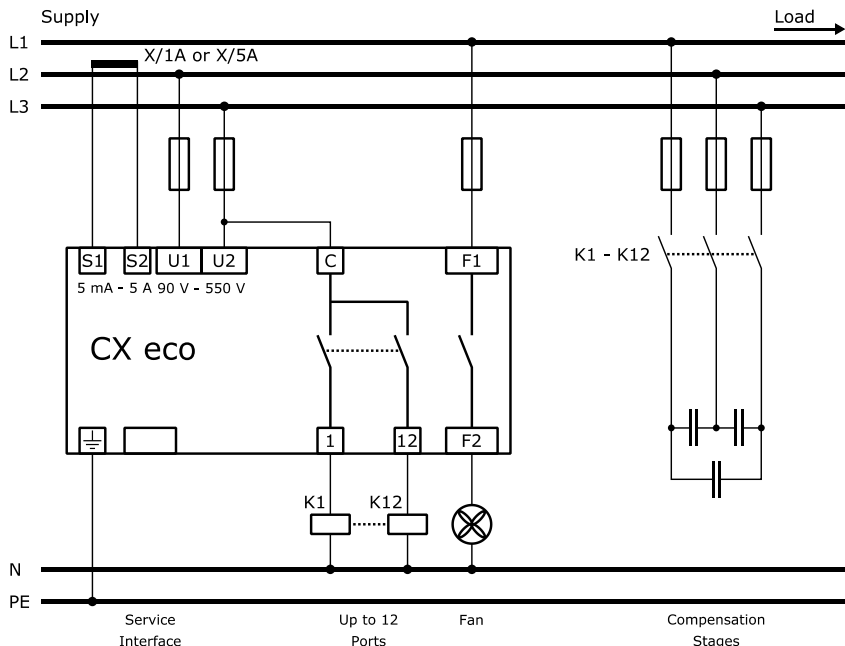

NOTE: The CX eco is designed to control **capacitive or inductive** stages. Operating both stage types simultaneously is not possible.

Installation and commissioning

- 1) Before installation, the connection specifications of the CX eco must be compared with the data of the power grid.
- 2) Disconnect the power supply and secured the working area against unauthorized and unintentional reconnection. Check if the disconnected area is voltage-free using a standardized measuring instrument. The voltage-free system must be earthed and short-circuited. Neighboring live parts must be covered and/or bypassed.
- 3) The current transformer must be short-circuited. A current transformer which has not been short-circuited generates a life-threatening voltage. This can lead to a destruction of the current transformer.
- 4) Insert the CX eco into the panel cut-out and fix it by using both fixing clamps.
- 5) Connect the grounding cable to the intended terminal on the backside of the device.
- 6) All cables must be connected as it is depicted in the connection diagram. The terminal K of the current transformer must be connected to terminal S1 and the terminal L to terminal S2.
- 7) Remove the short-circuit bridge at the current transformer.
- 8) The voltage can now be switched on.

- 9) If the device is connected correctly, the display will light up for one second and all symbols will be displayed during a display test.
- 10) Now, the current transformer factor must be entered.
- 11) If necessary, the nominal voltage and the voltage transformer factor must be adjusted.
- 12) The Automatic initialization (Ai) must be started (SETUP/100/Ai or SETUP/207 = **YES**).
- 13) After a successful Automatic initialization, the **AUTO** symbol appears in the displayed. When the discharge time has elapsed, the automatic control starts.

Frequently asked questions during commissioning

- 1) **AUTO is not shown** → control is switched off
Possible reasons: Manual operation activated; control is switched off; temperature is too high; current is less than 5 mA; voltage or THD of the voltage are inadmissible
- 2) **U ALARM is shown** → voltage is out of tolerance
Possible reasons: Nominal voltage (SETUP/Un) or voltage transformer factor is set incorrectly (SETUP/Pt)
- 3) **I Lo ALARM is shown** → measuring current is smaller than 5 mA
Possible reasons: Connection from the current transformer to the controller is incorrect; the current transformer jumper was not removed; current transformer ratio is too large; no current flow
- 4) **EXPORT is shown** → reverse current flow
Possible reasons: If there is no real reverse current flow, the voltage or current measurement is incorrect (phase, polarity)
- 5) **Wrong cos φ is shown** → incorrect connection
Possible reasons: Voltage or current measurement is incorrect (phase, polarity)
- 6) **Outputs are immediately switched off**
Possible reasons: Stage sizes in the stage database are incorrect
- 7) **Frequent switching operations**
Possible reasons: Capacitor capacity have not been recognized yet

Display

INFO
AUTO
MANUAL
SETUP
ALARM

AUTO or

no display:

Measurement menu

INFO:

Stage database

AUTO:

Control is on (no menu item)

MANUAL:

Manual mode

SETUP:

Controller settings

ALARM:

Alarm memory

EXPORT

ALARM

EXPORT:

Reverse current flow

ALARM:

Flashes if an alarm is pending

888^{ic}
1 2

First line

1: Power factor $\cos \varphi$ / Menu item

2: Inductive i / capacitive c

1 2 3
COS φ THDHar PΔQSU 888.888 kMC% s VAWvarh

Second line

1: Abbreviations

2: Measurement values / alarm codes

3: Units

Stage outputs

Stage status: On, off, faulty (flashing)

Stage data base: Selected stage flashes

1 2 3 4 5 6 7 8 9 10 11 12 13

Operation concept

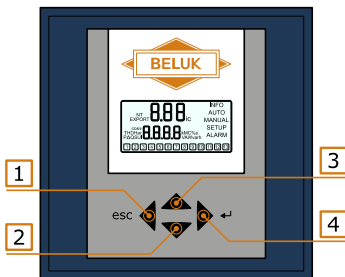

1

- Exit menu
- Move cursor to the left
- Reset alarm (push for 3 s)

2

- Decrease value
- Select next value, menu or stage number

3

- Increase value
- Select previous value, menu item or stage number

4

- Open menu
- Move cursor to the right
- Accept value

Entering values

If a menu item has been entered, the first digit of the current value flashes. Numbers can be increased or decreased by pushing the ▲ and ▼ keys.

The next digit can be selected by pushing the ► key. In order to select the previous digit, the ◀ key must be pushed.

If the last digit (right) has been selected and the ► key is pushed again, a multiplier **k** (kilo) or **M** (mega) can be set using the ▲ and ▼ keys. To accept the value and complete the entry, the ► key must be pushed again.

If an entered value has not been accepted, or if another value is displayed after an input, the entered value has exceeded or fallen below the threshold of the setting range.

An entry can be canceled at any time by pushing the ◀ key. Depending on the actual position, the ◀ key must be repeatedly pushed until the first digit (left) is selected. Pushing the ◀ key again exits the menu item without accepting changes.

Main menu

A menu can be selected by pushing ▲▼; Submenus are entered with ►

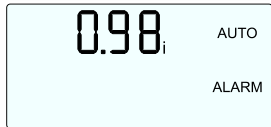
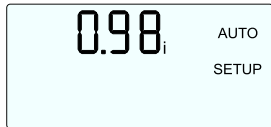
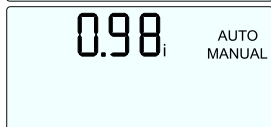
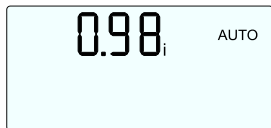

Measurement menu (Using ▲▼)

Retrieve measured values

INFO – Stage database

Contains the reactive power, power losses, amount of switching cycles and operating hours, stage type of each stage

MANUAL – Switching stages manually

Switching stage outputs manually

SETUP – Controller setup

Show and adjust all controller settings

ALARM – Alarm memory

Show the last 10 alarm messages. The newest alarm message is saved in location 1.

INFO – Stage database

Stages can be selected by ▲▼ and entered by pushing ►. The selected stage flashes. Using ▲▼, the following information can be shown.

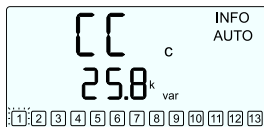

Current capacitor size

The reactive power value refers to the nominal voltage



Capacitor size in percent

Current reactive power to nominal reactive power ratio



Amount of switching cycles

Amount of completed switching operations



Stage type

AUTO: Stage is controlled automatically

FON: Stage is always on

FOFF: Stage is always off

FQty: Stage has been detected as faulty



Operating hours

Amount of operating hours

MANUAL – Switching stage outputs manually

In order to enter the MANUAL menu, the ► key must be pushed for 3 seconds.

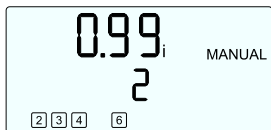

▲▼ to select a stage. The selected stage is shown in the lower part of the display. A stage is switched on or off by pushing the ► button.

The MANUAL menu can be exit by pushing the ◀ key.

Important information:

- Only stages of the type **AUTO** can be manually switched.
- The discharge time is considered in manual mode as well. After switching a stage off, it is locked until the discharge time has been expired.
- The measured voltage must be within the set tolerance. If the voltage is out of tolerance, every stage is switched off and cannot be switched on again.
- As soon as the MANUAL menu is left, the control automatically starts again.

SETUP – Controller setup

The Quick Start menu (100) and the Expert menus (200 – 800) can be entered by pushing the ► button. The latter one requires the input of a PIN code.

Un **Nominal voltage**

Ct **Current transformer factor**

Pt **Voltage transformer factor**

Ai **Automatic initialization**

The phase angle between voltage and current is determined and which stage outputs are used.

PFC **Control ON, OFF, Hold**

Switching on, off or suspend the control

CP1 **Target-cosφ 1**

Compensation target

St **Switching time**

Delay between switching different stages

Out **Stage type AUTO, FON, FOFF, Flty**

Stages are controlled automatically, are permanently on, permanently off or detected as faulty. **AUTO**, **FON** and **FOFF** can be adjusted and **Flty** stages can be reset.

Automatic initialization (Ai)

The Automatic initialization determines the phase angle between voltage and current and detects which stage outputs are used.

The Automatic initialization can be activated in the SETUP menu (SETUP/100/Ai or SETUP/207 = **YES**) and starts as soon as the voltage is within the tolerance and the measured current is greater than 5 mA. The display shows **Ai run** and the **number** of the active run. At the end of the Ai, the function of the controller must be checked.

NOTE: The Automatic initialization is only possible in conjunction with capacitive stages.

Due to load fluctuations, it may happen that the Ai does not correctly recognize used stage outputs or is aborted. The latter one is displayed by the error message **Ai / Abrt**. In this case, the control is stopped.

If the Automatic initialization is not successful after several attempts, the correct phase correction angle must be set manually (SETUP/206). Moreover, the stage types must be adjusted manually (SETUP/100/Out or SETUP/403) and the control must be started again (SETUP/100/PFC or SETUP/310 = **ON**).

Automatic stage size detection

If stage detection is activated (SETUP/308 = **YES**), the CX eco determines the size of the stages automatically during each switching operation. The detected sizes are stored in the stage database. There, a stage power loss can be monitored.

If the controller cannot detect a power grid reaction during the first three switching operations, the stage type of the affected stage is set to **FOFF** and it is not taken into account by the control.

NOTE: The automatic stage detection is only possible in conjunction with capacitive stages. The use of inductive stages requires a manual input of the stage sizes (SETUP/402).

Detect faulty stages

Stages whose size has already been adopted are classified as faulty by the control system after three successive switching operations without a power grid reaction. A new check is performed after 24 hours.

Faulty stages have the stage type **Filty** and are indicated by a flashing stage symbol.

The cause of a faulty stage could possibly be a defective fuse, a defective power contactor or a defective capacitor stage.

Most important Alarm and Error messages

U	ALARM	The measured voltage is out of the set tolerance.
I Lo	ALARM	The measured current is smaller than 5 mA.
I hi	ALARM	The measured current is higher than 6 A.
PFC	ALARM	The compensation target cannot be reached.
HArU	ALARM	Set THD voltage threshold exceeded.
HArl	ALARM	Set THD current threshold exceeded.
StEP/FltY	ALARM	At least one stage is faulty.
SPL/Nr	ALARM	The reactive power of at least one stage has fallen below 75 % of the initial power value.
thi	ALARM	Second temperature threshold exceeded.
OPh	ALARM	Operating hours of the controller exceeded.
OPC/Nr	ALARM	Switching cycles of at least one stage exceeded.
OPh/Nr	ALARM	Operating hours of at least one stage exceeded.
SYS/004F	ALARM	A system alarm is triggered. The device is defective and must be returned to BELUK GmbH.
Ai/Abrt	ALARM	The Automatic initialization has been aborted due to an error. The control is switched off.

Factory settings

SETUP/100 Quick Start	open	304/ -	---
Un/ Nominal voltage	400 V	305/ Switching time	10 s
Ct/ Current transformer factor	1	306/ Sw. time stage exchange	2 s
Pt/ Voltage transformer factor	1	307/ Stage exchange	YES
Ai/ Start Ai	NO	308/ Stage detection	YES
PFC/ Control	ON	309/ Block faulty stages	YES
CP1/ Target-cos ϕ 1	1	310/ Control	ON
St/ Switching time	10 s	311/ Control algorithm	1
Out/ Stage type	AUTO	312/ Reactive power offset	0 var
		313/ -	---
SETUP/200 Measurement	locked	314/ Switch off if Q is cap	NO
201/ Nominal voltage	400 V	315/ Distribute sw. operations	NO
202/ Current transformer factor	1	316/ Detect faulty stages	YES
203/ Voltage transformer factor	1		
204/ Voltage tolerance	10 %	SETUP/400 Stage database	locked
205/ Meas. connection	U-LN/U-LL	401/ Discharge time	75 s
206/ Phase correction angle	0	402/ Nominal stage size	c 3 var
207/ Start Ai	NO	403/ Stage type	AUTO
208/ Sync. frequency	AUTO	404/ Switch operat. counter	0
209/ Temperature offset	0 °C	405/ Operat. hours counter	0 h
		406/ Fan relay as stage output	NO
SETUP/300 Control	locked		
301/ Control sensitivity	60 %		
302/ Target-cos ϕ 1	1.00		
303/ -	---		

SETUP/500 Alarm	locked	SETUP/600 Reset menu	locked
501/ Reset alarms manually	NO	601/ Factory reset	NO
502/ THD-U threshold	20 %	602/ Stage database	NO
503/ Switch off stages	NO	603/ Operating hours	NO
504/ THD alarm delay	60 s	604/ Average power factor	NO
505/ Stop control if I=0	NO	605/ Max. temperature	NO
506/ Service alarm	NO	606/ Alarm memory	NO
507/ Max. OPc stages	500 k	607/ Info firmware	---
508/ Max. OPh controller	65.5 kh	608/ Change password	242
509/ Max. OPh stages	65.5 kh	609/ -	---
510/ THD-I threshold	50 %	SETUP/700 -	---
511/ -	---		
512/ TEMP1 threshold	30 °C	SETUP/800 System	locked
513/ TEMP2 threshold	55 °C	801/ Backlight during	NO
514/ Control alarm	NO	Commissioning mode	
515/ Faulty stages alarm	NO	802/ Backlight duration	0.25 h
516/ Stage power loss alarm	NO		
517/ Flashing display	NO		
518/ -	---		
519/ -	---		
520/ -	---		
521/ -	---		
522/ I-High alarm delay	10 s		
523/ Switch-off interval	60 s		

Specifications

Voltage measurement / supply:	Connection: Single phase Range: 90 – 550 V AC, 45 – 65 Hz Protection: Max. 6 A Power consumption: 6 VA Transformer factor: Adjustable 1.0 ... 350.0
Current measurement:	Connection: Single phase Range: 5 mA – 5 A Transformer factor: Adjustable 1 ... 9600
Stage outputs:	6 or 12 Stage outputs Type: Relay, normally-open, potential-free Supply: Common, max. 10 A Swit. capacity per relay: 250 V AC / 5 A 400 V AC / 1 A 48 V DC / 1 A 110 V DC / 0.2 A
Temperature measurement:	Type: NTC under the housing cover Accuracy: +- 5 °C
Fan output:	Type: Relay, normally-open, potential-free Switching capacity: 250 V AC / 5 A 400 V AC / 1 A 48 V DC / 1 A 110 V DC / 0.2 A
Service Interface:	For service purpose only

Ambient temperature:	Operating: -20 °C – 70 °C Storing: -40 °C – 85 °C
Humidity:	Range: 0 % – 95 % Condensation: Not allowed
Overvoltage category:	300 V _{LN} / 519 V _{LL} → CAT III 519 V – 550 V → CAT II Degree of contamination → 2
Standards:	IEC 61010-1, IEC 61000 6-2, IEC 61000 6-4: Level B, IEC 61326-1, UL 61010
Compliance and Listing:	CE, c NRTL us (c UL us), EAC
Connections:	Type: Screw terminals, pluggable Cross section: Max. 4 mm ²
Housing:	Front: Plastic housing (UL94 V-0) Back: Metal cover
Protection class:	Front: IP41 Back: IP20
Weight:	Approx. 0,6 kg
Dimensions:	Device: H x B x T: 144 x 144 x 58 mm Cut-out: H x B: 138 (+0,5) x 138 (+0,5) mm